

PC

系列 空氣調理組合(三點組合)

series F.R.L. COMBINATION UNIT

模組型式 F.R.L 組合 Modular F.R.L Unit

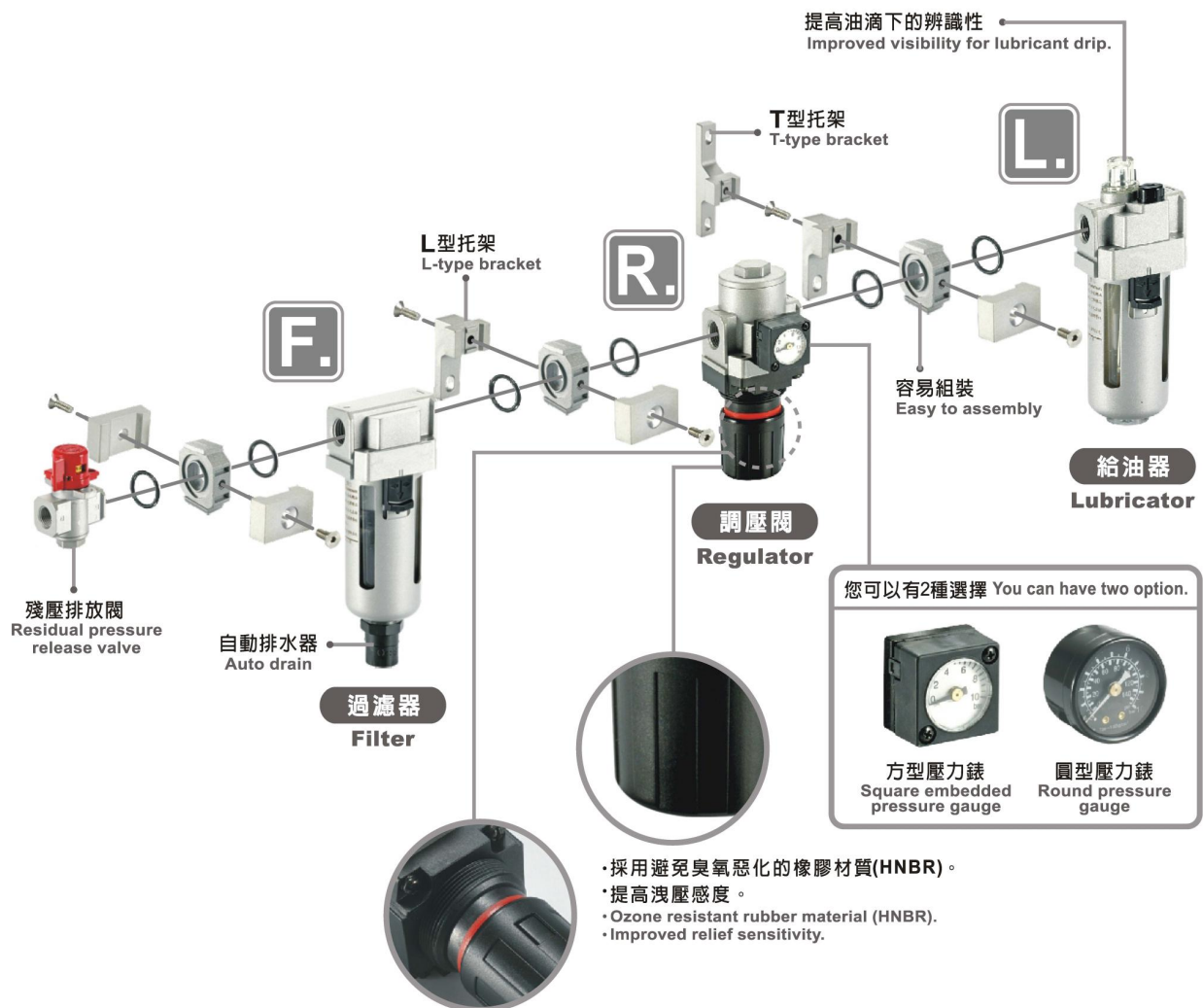

- 採用避免臭氧惡化的橡膠材質(HNBR)。
- 提高洩壓敏感度。
- Ozone resistant rubber material (HNBR).
- Improved relief sensitivity.

橘色記號 (ORANGE MARK)

可依顏色指示做鎖定壓力或調整壓力的功能。
You can "ORANGE MARK" to lock or regulate the pressure.

三點組合 (PC)

F.R.L. Combination Unit

標準組合表 Standard Combinations

構成組合 Model	型式 Type	接管口徑 Port Size G / NPT	構成機器 Component				
			過濾器 Air Filter PF	調壓閥 Regulator PR	給油器 Lubricator PL	調壓過濾閥 Filter Regulator PW	油霧分離器 Mist Separator PFM
	PC2000	1/8", 1/4"	PF2000	PR2000	PL2000		
	PC3000	1/4", 3/8"	PF3000	PR3000	PL3000		
	PC4000	1/2", 3/4"	PF4000	PR4000	PL4000		
	PC2010	1/8", 1/4"			PL2000	PW2000	
	PC3010	1/4", 3/8"			PL3000	PW3000	
	PC4010	1/2", 3/4"			PL4000	PW4000	
	PC2020	1/8", 1/4"	PF2000	PR2000			
	PC3020	1/4", 3/8"	PF3000	PR3000			
	PC4020	1/2", 3/4"	PF4000	PR4000			
	PC2030	1/8", 1/4"	PF2000	PR2000			PFM2000
	PC3030	1/4", 3/8"	PF3000	PR3000			PFM3000
	PC4030	1/2", 3/4"	PF4000	PR4000			PFM4000
	PC2040	1/8", 1/4"				PW2000	PFM2000
	PC3040	1/4", 3/8"				PW3000	PFM3000
	PC4040	1/2", 3/4"				PW4000	PFM4000

其他組合方式 Other Combinations



三點組合 (PC)

F.R.L. Combination Unit

訂購代號 Order No.

PC 30 00 03 DKT P20

空氣組合 Air combination

本體尺寸 Body size

20	1/8", 1/4"
30	1/4", 3/8"
40	3/8", 1/2, 3/4"

組合型式 Model combination

記號 Code	構成機器 Component				
	過濾器 Air Filter	調壓閥 Regulator	給油器 Lubricator	調壓過濾器 Filter Regulator	油霧分離器 Mist Separator
00	①	②	③	—	—
10	—	—	②	①	—
20	①	②	—	—	—
30	①	③	—	—	②
40	—	—	—	①	②

- 內的數字，表示從上流側(一次側)開始的構成順序。
- Order of assembly.

螺牙的種類 Port thread

	G (PS)
N	NPT

接管尺寸 Port size

記號 Code	口徑 Port size	本體尺寸 Body size		
		20	30	40
01	1/8"	●	—	—
02	1/4"	●	●	—
03	3/8"	—	●	●
04	1/2"	—	—	●
06	3/4"	—	—	●

● 附屬裝置 Attachment

記號 Code	名稱 Description	
P	殘壓排放三口閥 3-port valve for residual pressure release	 A-37
P1	壓力開關 Pneumatic pressure switch	 A-39
P20	數位壓力開關 Digital pressure switch	 A-41

- 適用機種：PC2000-PC4000, PC2010-PC4010, PC2020-PC4020, PC2030-PC4030, PC2040-PC4040。
- Applicable model: PC2000-PC4000, PC2010-PC4010, PC2020-PC4020, PC2030-PC4030, PC2040-PC4040.

● 選配 Accessory

記號 Code	內容 Description	
D	自動排水(N.C) Auto drain	
E	配管接頭 Piping adaptor	 A-38
GK	方形壓力錶 Square embedded pressure gauge	 A-36
H	手動排水 Manually control drain	
K	圓形壓力錶 Round pressure gauge	 A-36
L	L型托架 L-type bracket	 A-34
T	T型托架 T-type bracket	 A-34
R	流動方向：右→左 Flow direction: right to left	
W	托架 Bracket	 A-35
Y	T型分歧塊 T-interface	 A-33

- 有2記號以上重覆時，請依羅馬拼音排列。
- 適用機種：PC20□-PC40□
- When more than one attachment or accessories are required, order in alphabetical order.
- Applicable model: PC20□-PC40□

PC 系列 空氣調理組合(三點組合)

series F.R.L. COMBINATION UNIT



Symbol

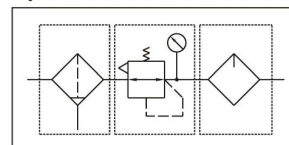

本體材質鋁合金壓鑄

The body is made of die casting aluminum alloy.

規格表 Specifications

型式 Type		PC2000	PC3000	PC4000
構成機器 Component	過濾器 Air Filter	PF2000	PF3000	PF4000
	調壓閥 Regulator	PR2000	PR3000	PR4000
	給油器 Lubricator	PL2000	PL3000	PL4000
接管口徑 Port size (G)		1/8", 1/4"	1/4", 3/8"	1/2, 3/4"
壓力錶接管口徑 Port size for pressure gauge (G)※		1/8"	1/8"	1/4"
使用流體 Fluid		空氣 Air		
保證耐壓力 Proof pressure (kgf/cm ²)		15		
最大使用壓力 Max. operating pressure (kgf/cm ²)		10.2		
調壓範圍 Regulating range (kgf/cm ²)		0.5 ~ 8.7		
環境和介質溫度 Ambient and media temperature (°C)		-5 ~ 60 (無凍結狀態)With no freezing		
過濾精度 Nominal filtration rating (μm)		標準 Standard: 5 / 選項 Option: 0.01, 0.3, 2		
建議用油 Recommended oil		ISO VG32		
杯材料 Bowl material		聚碳酸酯 Polycarbonate		
重量 Weight (kg)		0.5	1.2	2.3

※只適用於圓形壓力錶 (Only for round gauge)

選配零件/附屬裝置 Accessory (Optional) / Attachment

名稱 Name	型式 Type	零件型式 Part No.			參考頁數 Reference Page		
		PC2000	PC3000	PC4000			
選配零件 Accessory (Optional)	壓力錶 Pressure gauge	10 kgf/cm ²	圓形 Round	K40110	K40110	K40210	A-36
			方形 Square	GK27510	GK27510	GK27510	A-36
		4 kgf/cm ²	圓形 Round	K40104	K40104	K40204	A-36
	自動排水 Auto drain	浮球式N.C (Float type)※		—	AD53	AD53	—
		差壓式(Differential pressure type)		AD62	—	—	—
	配管接頭 Piping adaptor		—	E30-04	E40-10	A-38	
	T型分歧塊 T-type spacer		Y21-M5	Y31-02	—	A-33	
	L型托架 L-type bracket		B210L	B310L	B410L	A-34	
	T型托架 T-type bracket		B210T	B310T	B410T	A-34	
	O型隔板 O-type spacer		Y20	Y30	Y40	A-33	
2通口分歧塊 Cross interface		—	Y32-02	Y42-04	A-38		
附屬裝置 Attachment	殘壓排放閥 Residual pressure release		PHS2000-02	PHS3000-03	PHS4000-06	A-37	
	壓力開關 Pressure switch		P1-□	P1-□	P1-□	A-39	
	數位壓力開關 Digital pressure switch		P20□	P20□	P20□	A-41	

※最小操作壓力 (Mini operating) : N.C - 1.5 kgf/cm²

三點組合 (PC)

F.R.L. Combination Unit

尺寸圖 Dimension

PC2000-01 (1/8")

PC2000-02 (1/4")

 PC2000

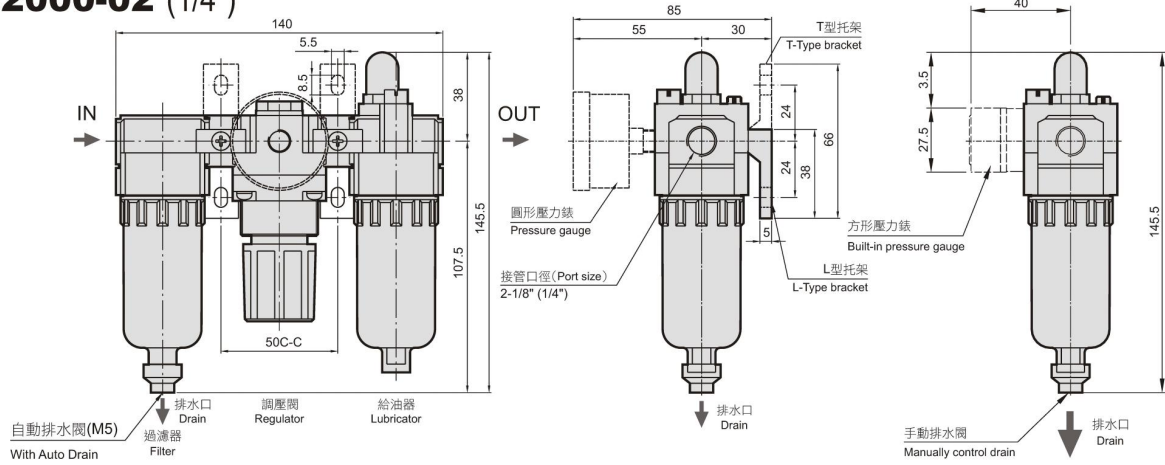

PC3000-02 (1/4")

PC3000-03 (3/8")

 PC3000

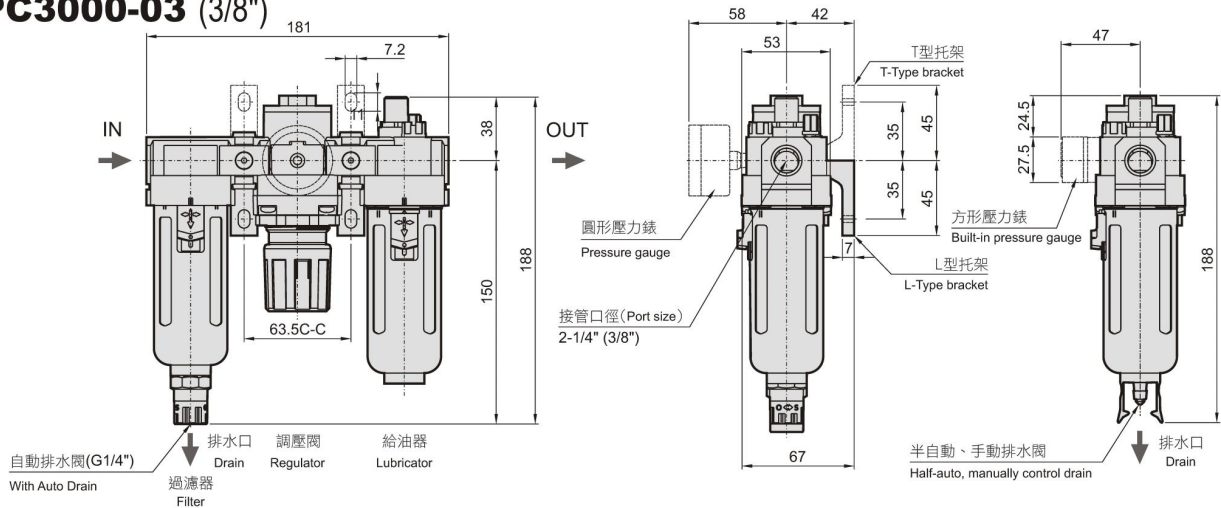

PC4000-04 (1/2")

PC4000-06 (3/4")

 PC4000

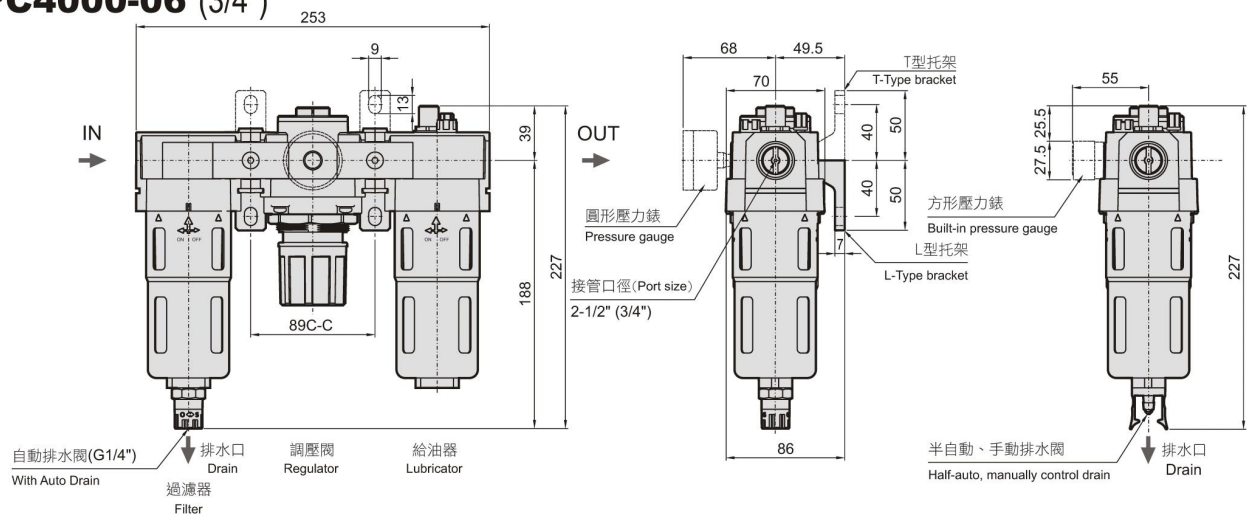

三點組合 (PC)

F.R.L. Combination Unit

流量特性 Flow Characteristics

PC2000

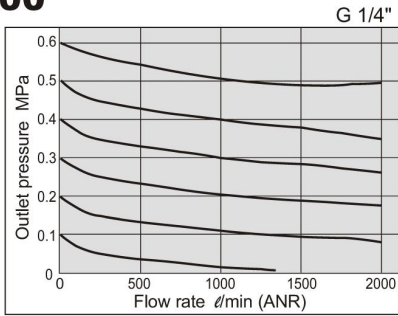

壓力特性 Pressure Characteristics

PC2000

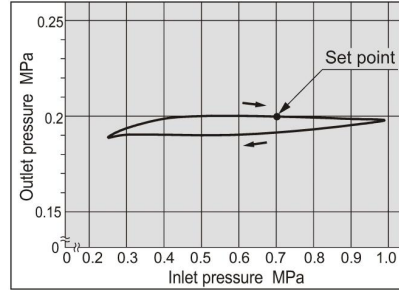

PC3000

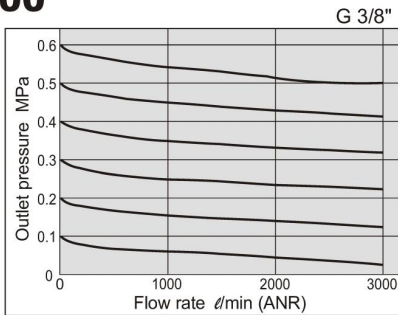

PC3000

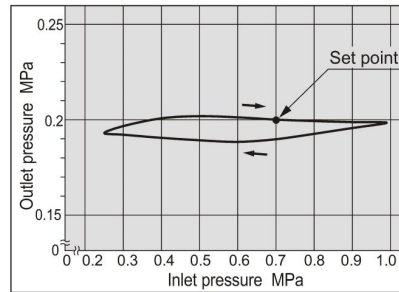

PC4000

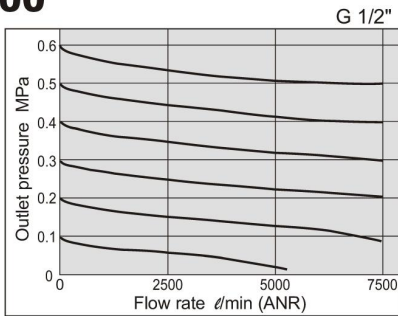

PC4000

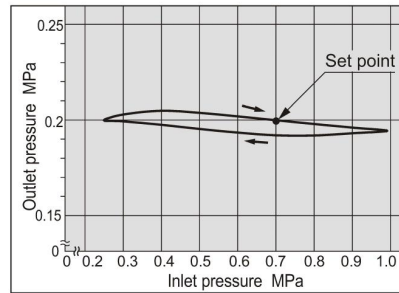

PC4000-06

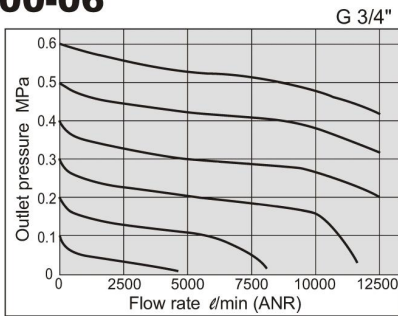

PC4000-06

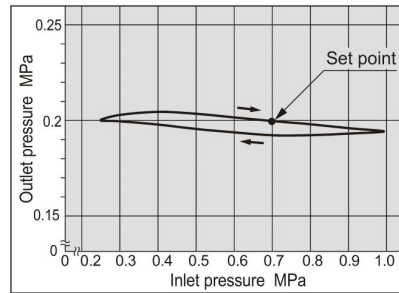

使用注意事項 Specific Product Precautions

選擇

警告

①有關浮球式自動排水

為避免作動不良，請根據以下條件使用。

- 請使用0.75kW[100ℓ/min(ANR)] 以上的壓縮器。

另外，使用2個以上自動排水時，上記壓縮器的能力，請使用乘以其使用數量能力的壓縮器。

使用2個時，必須具備1.5kW[200ℓ/min(ANR)] 以上能力的壓縮器。

- 使用壓力請使用10 kgf/cm²以上。

(N.C.型式的情形)

- AD53、62的使用壓力為10 kgf/cm²以上。

②在調壓閥、調壓過濾閥IN側安裝殘壓排放3口閥時，請使用附逆流機能減壓閥、調壓過濾閥。

注意

- ①在給油器的一次側安裝T型承接器進行中間取出時，油可能有逆流的情形，無法進行無給油空氣的取出。
- ②潤滑油的IN側若安裝殘壓排放3口閥時，會有逆流情形，因此請於EXH通口上安裝排氣清淨器等，以防止油飛散。
- ③在工廠出貨的空氣組合上雖然貼有規格標示牌，但是在流通通路組裝的製品上，沒有貼上空氣組合規格標示牌。
- ④在殘壓排放3口閥的OUT側安裝壓力開關、T型承接器、調壓過濾閥時，請另行確認。

空氣來源

注意

- 安裝殘壓排放3口閥時，為避免垃圾屑等造成的薄板部的損傷，請於一次側上裝置濾過度5 μm以下的空氣過濾器。

Selection

Warning

①Float type auto drain

Operate under the following conditions to avoid malfunction.

- Operating compressor: 0.75kW[100ℓ/min(ANR)] or more.

When using 2 or more auto drains, multiply the value above by the number of auto drains to find the capacity of the compressors you will need.

For example, when using 2 auto drains, 1.5kW [200ℓ/min(ANR)] of the compressor capacity is required.

- Operating pressure: 10 kgf/cm² or more.

(N.C. type)

- Operating pressure for AD53, AD62: 10 kgf/cm² or more.

②Use a regulator or filter regulator with a back flow mechanism when mounting a 3-port valve for residual pressure release on the IN side to ensure the release of the residual pressure. Otherwise, residual pressure will not be fully released.

Caution

- ①When releasing air at the intermediate position using a T-interface on the inlet side of the lubricator, lubricant may back flow.
Therefore, releasing air that does not contain traces of lubricant is not possible.
- ②Mounting a 3-port valve for residual pressure release on the IN side of the lubricator can cause lubricant to back flow.
Take measures to prevent lubricant from splashing by installing a filter on the EXH port.
- ③An F.R.L. unit shipped from the plant has its model number labeled. However, components that are combined together during the distribution process do not have a label on them.
- ④Contact SMC when mounting a pressure switch, T-interface, or filter regulator on the OUT side of the 3-port valve for residual pressure release.

Air Supply

Caution

- Use an air filter with 5μm or less filtration rating on the inlet side of the valve to avoid any damage to the seat caused by dust when mounting a 3-port valve for residual pressure release on the inlet side.